

STANDARD DOOR SETOUT  
(CAN VARY)

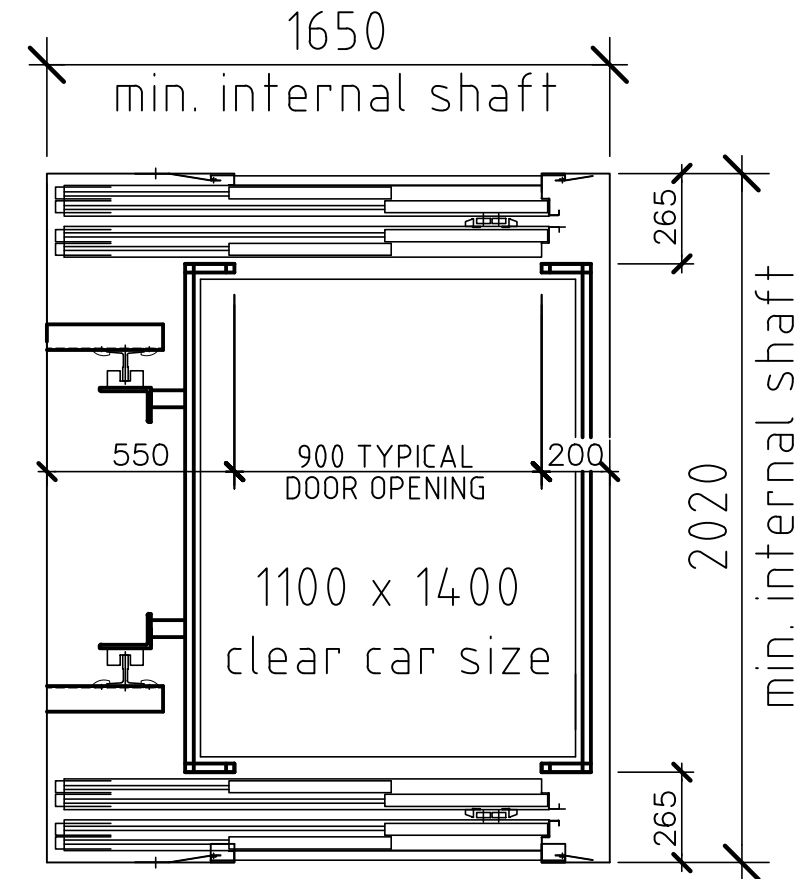

ACCESS SOLUTIONS SUPPLIED SHAFT — OR — BUILDER SUPPLIED SHAFT  
 SAVES EVERYONE TIME AND MONEY AND CAN  
 BECOME PART OF THE BUILDING STRUCTURE  
 TO SUPPORT OTHER MEMBERS  
 (CRANED IN FROM ABOVE)

SIDE OPENING DOORS (RIGHT)  
 THROUGH CAR

ELEVATOR TYPE	MOTOR ROOMLESS
RATED LOAD	320 Kg
N° OF PASSENGERS	4 PERSONS
DRIVE	DRUM DRIVE
SPEED (m/s)	0.25 m/s
DRIVE CONTROL	VF
ROPE SUSPENSION	1:1
GEAR RATIO	GEARLESS
LANDINGS	G,1
MAIN FLOOR	GROUND FLOOR
TRAVEL	T.B.C.
SHAFT HEIGHT	T.B.C.
PIT DEPTH	150mm
CAR SIZE	1100 WIDE x 1400 DEEP
CAR HEIGHT	2200 CLEAR
DOOR OPENING	2100 HIGH x 900 WIDE



86 Burwood Drive  
 Blackmans Bay  
 Tasmania 7052  
 PO BOX 161 Kingston  
 P. (03) 6229 2476  
 info@access-solutions.com.au  
 www.access-solutions.com.au